

ARCHITECTURAL SERIES

AR - 1202_{RTC}

12 CHANNEL X 2.4KW
ARCHITECTURAL DIMMER

OWNERS MANUAL

Revision 1.93
06/03/2008

AR – 1202RTC ARCHITECTURAL DIMMER

Revision 1.93

OWNERS MANUAL

06/03/2008

TABLE OF CONTENTS

AR-1202 UNIT DESCRIPTION	3	EVENT SYSTEM OPERATION	15
EXTERNAL CONTROLS	3	Setting the Internal Clock	15
REAL TIME CLOCK EVENT SYSTEM	3	Setting the Date	15
POWER REQUIREMENTS	3	Setting the Time of Day	15
INSTALLATION	3	Setting the Day of the Week	15
Physical Location	3	Creating and Editing Events	15
Power Input Connections	3	Event System Enable	16
Three Phase Power Connections	4	To Control Event Triggering	16
Single Phase Power Connections	5	Programming Events	16
External Connections	6	Selecting an Event	17
Lighting Load Connections	6	Assigning a Scene and Scene Action	17
Control Signal Connections	6	Choosing Day Based or Date Based Triggers	17
DMX Console Connections	7	Setting Date Based Triggers	17
DMX Termination	7	Setting Day Based Triggers	17
Smart Remote Connections	8	MAINTENANCE AND REPAIR	18
Simple Remotes Connections	9	Owner Maintenance	18
AR-1202 Unit Setup	9	Internal Fuse	18
Using The Menu System	10	Operating And Maintenance Assistance	18
System Mode	10	CONTROL CIRCUIT BOARD CONNECTIONS	19
System Power Setup	10	DIMENSIONS AND MOUNTING	20
Unit Address Assignment	11	AR-1202 UNIT SPECIFICATIONS	21
Dimmer Channel Setup	11	WARRANTY	22
Channel Limiting	11		
Channel Non-Dim (Relay) Mode	11		
DMX I/O Setup (Dimmer Channel Assignment)	12		
Console Lockout	12		
Remote Lockout	12		
Creating And Editing Scenes	12		
To Create A Scene Manually	13		
To Copy a Scene	13		
To Record a Live Scene	13		
Scene Fade Time	13		
Scene Blackout Fade Time	13		
OPERATION	14		
Manual Operation	14		
DMX Console Operation	14		
Smart Remotes Operation	14		
Button And IR Smart Remotes Operation	14		
Fader Smart Remotes Operation	14		
Simple Remotes Operation	15		

AR-1202 UNIT DESCRIPTION

The AR-1202 consists of an embedded micro processor and 12 dimmer channels of 2.4KW each. Each dimmer channel is protected by a 20 Amp circuit breaker. Heavy duty filtering chokes are used to reduce noise. Dimmer channel semiconductors exceed a 200% load carrying capacity overhead allowance. All components and sub systems are UL recognized components. All internal wiring conforms to UL standards as they apply to industrial controls. Dimensions and weight information is given at the end of this manual.

EXTERNAL CONTROLS

The AR-1202 can communicate with remotely located control equipment in several ways.

A USITT DMX-512 protocol bus is provided so the unit may be used with any DMX lighting console. The AR-1202 is fully patchable with respect to the DMX bus.

The AR-1202 may also be controlled by several types of wall mounted smart remote stations. Smart remotes communicate with the AR-1202 by way of a low voltage RS-485 bus. This bus is completely separate from the DMX bus. Smart remotes are used to activate preset scenes which have been stored in the AR-1202. There are several types of smart remote stations. Multiple smart remotes of the same or different types may be chained together on the RS-485 bus. The same RS-485 bus may be chained to multiple AR-1202 dimmer packs.

The AR-1202 may additionally be controlled by an arrangement of one or more momentary switches (simple remotes). The switches may be used to control a specific set of scenes stored in the AR-1202.

REAL TIME CLOCK EVENT SYSTEM

The AR-1202 contains an internal clock and timer sub system. This subsystem may be used to create events which activate and switch between preset lighting scenes based upon times, days, and dates. A total of 128 events may be programmed.

POWER REQUIREMENTS

The AR-1202 may be operated from 50/60 Hz, 120/208 VAC, three phase power or from 50/60 Hz, 120/240 VAC, single phase power. Input power to the unit must be capable of delivering 80 Amps per line if using three phase or 120 Amps per line if using single phase power.

The AR-1202 can operate using only 2 phases of a 3 phase power source. This is **NOT RECOMMENDED** since it causes an unbalanced load at the power feed source.

The AR-1202 is must be used with a WYE connected power source. A NEUTRAL line is required.

INSTALLATION

PHYSICAL LOCATION

The unit is intended for **INDOOR OPERATION ONLY** and should not be subjected to excessive moisture or heat. The unit should be installed where a supply of circulating air is available. The AR-1202 is designed to be wall mounted in a equipment room or electrical distribution area. The ambient air in the installation area should be below 86 deg F.

The AR-1202 is convection cooled by heatsinks on the left and right sides of the unit. Provide spacing between the unit and other equipment to allow air flow around the unit (particularly around the finned heat sinks). See “Dimensions and Locations” in this manual for more information concerning mounting of the unit.

POWER INPUT CONNECTIONS

**WARNING**

**MAKE CERTAIN POWER IS REMOVED
FROM THE FEED CIRCUITS
BEFORE YOU BEGIN INSTALLATION.**

Consult applicable electrical codes to determine the proper wire type and methods.



The AR-1202 operates using either 3 phase 120/208 VAC or single phase 120/240 VAC power. The unit is shipped from the factory as a **THREE PHASE** unit. It can be field converted to single phase unit.

AR – 1202RTC ARCHITECTURAL DIMMER OWNERS MANUAL

Revision 1.93

06/03/2008

THREE PHASE POWER CONNECTIONS

WARNING

MAKE CERTAIN POWER IS REMOVED
 FROM THE FEED CIRCUITS
 BEFORE YOU BEGIN INSTALLATION.

REQUIREMENTS

Actual 120/208VAC three phase power must be supplied to operate the AR-1202 in the 3 phase configuration. This means that the voltage across any two lines must be 208 VAC. The feed circuit must be able to supply 80 Amps for each hot line.

THE AR-1202 WILL NOT OPERATE IN A THREE PHASE CONFIGURATION FROM 2 LINES OF EITHER A SINGLE OR 3 PHASE SUPPLY CIRCUIT.

CONNECTIONS

Connect the 3 in hot feed lines to the 3 terminals on the input power terminal block (**H1, H2, H3**).

Connect the feed neutral to the NEUTRAL bus bar.

Connect the feed ground to the GROUND lug.



HIGH VOLTAGE CIRCUITRY IS EXPOSED WHEN THE CABINET DOOR IS OPEN. DO NOT ALLOW THE UNIT TO OPERATE OR HAVE POWER APPLIED TO IT WHILE THE DOOR IS OPEN.

See the section **SYSTEM POWER SETUP** for operation using 3 phase connections.

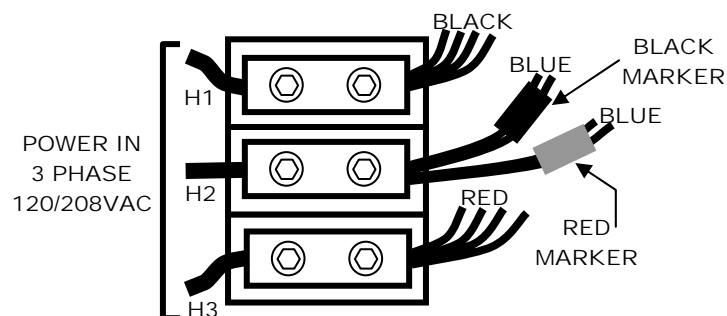
THREE PHASE POWER CONNECTIONS



SINGLE PHASE POWER CONNECTIONS

 **WARNING** 
 MAKE CERTAIN POWER IS REMOVED
 FROM THE FEED CIRCUITS
 BEFORE YOU BEGIN INSTALLATION.

REQUIREMENTS

The RA-122 can operate as a single phase unit using only 2 phases of a 3 phase power source. This is **NOT RECOMMENDED** since it causes an unbalanced load at the power source.

The feed circuit must be able to supply 120 Amps for each line.

CONNECTIONS

There are three terminals on the input power terminal block (**H1, H2, H3**). When operating the AR-1202 on single phase power, the center (**H2**) terminal is not used.

The wires connected to the left side of the H2 terminal contain color coded sleeves (RED and BLUE). These wires must be moved and distributed to the H1 and H3 terminals. Remove the wires from the H2 terminal and connect them to H1 and H3 such that the sleeve color matches the wire colors on H1 and H3.

Connect the feed neutral to the NEUTRAL bus bar.

Connect the feed ground to the GROUND lug.

HIGH VOLTAGE CIRCUITRY IS EXPOSED WHEN THE CABINET DOOR IS OPEN. DO NOT ALLOW THE UNIT TO OPERATE OR HAVE POWER APPLIED TO IT WHILE THE DOOR IS OPEN.

SINGLE PHASE POWER CONNECTIONS

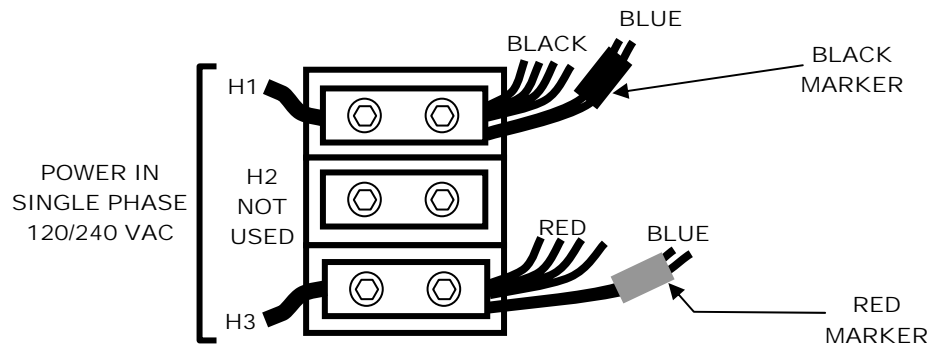

EXTERNAL CONNECTIONS

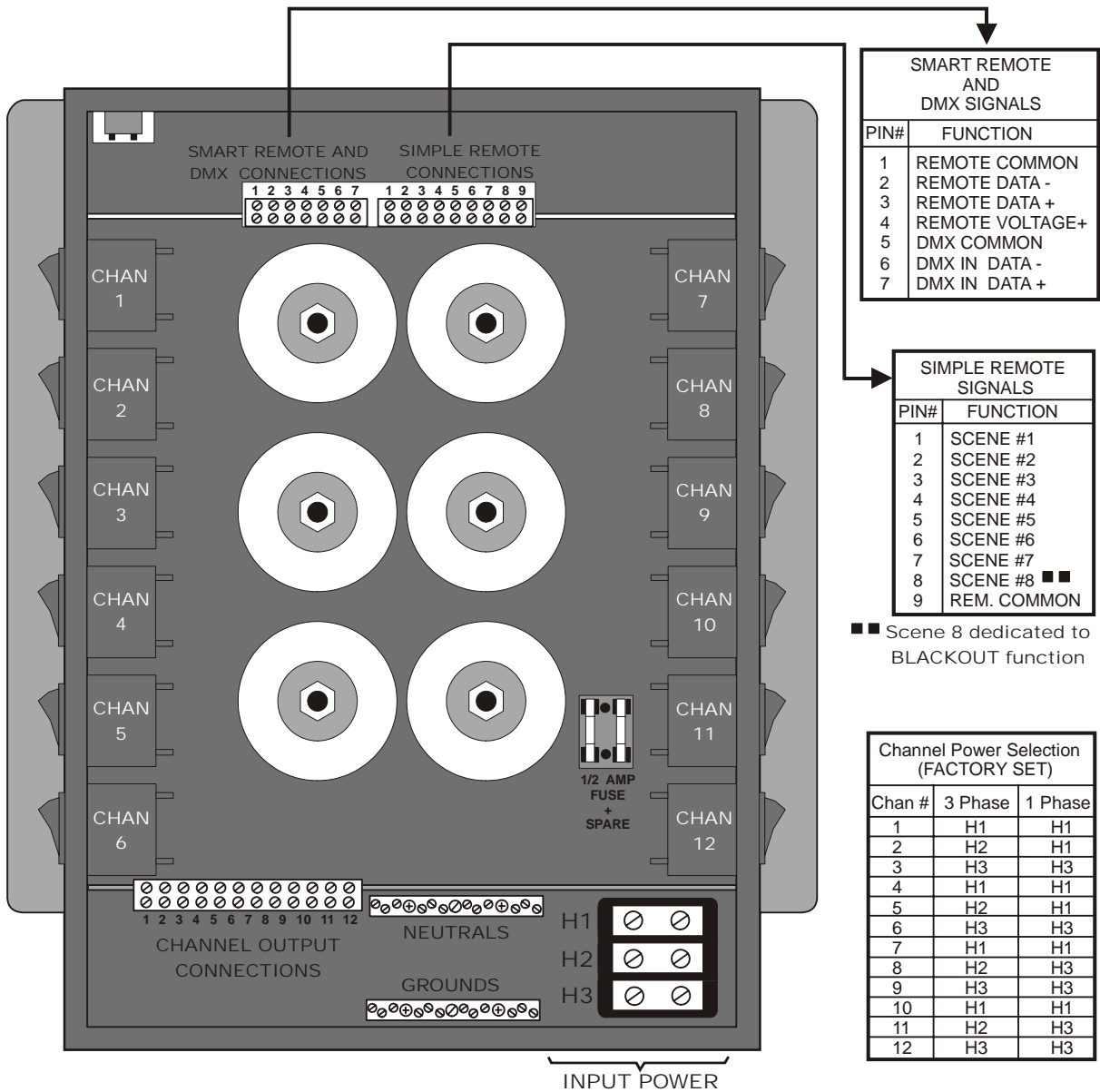

LIGHTING LOAD CONNECTIONS

Lighting to be controlled by the AR-1202 must be connected to the terminal strip located on the front of the lower separator panel of the cabinet. The lowest number dimmer channel output connection is on the left. See the EXTERNAL CONNECTIONS DIAGRAM. Above. The load connections terminal strip is shown as CHANNEL OUTPUT CONNECTIONS in the diagram.

CONTROL SIGNAL CONNECTIONS

Terminal strips are provided for connection to DMX consoles, smart remotes, and simple remote stations. Specific wiring connection point information for all external control signals is shown in the EXTERNAL CONNECTIONS diagram above.

DMX CONSOLE CONNECTIONS

DMX console signals to the AR-1202 should be transmitted over a twisted pair, shielded, low capacitance cable. A DMX console transmits from a female, 5 Pin XLR Connector.

See the EXTERNAL CONNECTIONS and the example below for specific connection information.

**DMX CABLE
CONDUCTOR ARRANGEMENT FOR
TWISTED PAIR, SHIELDED CABLE**

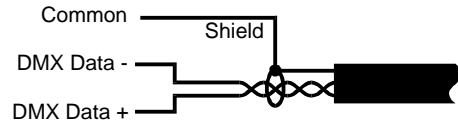

DMX TERMINATION

A DMX bus should be terminated (only) at the last receiving device on the chain. This is done by connecting a 120 ohm, 1/4 watt resistor across the DMX DATA - and DMX DATA + lines.

A DMX bus should be daisy chained to all its receiving units. It should NOT be connected in a star arrangement with multiple "home runs".

**CONSOLE DMX OUTPUT CONNECTOR
(5 PIN FEMALE XLR)**

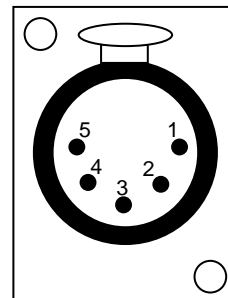

CAUTION
REMOVE ALL POWER FROM THE AR-1202
BEFORE MAKING OR CHANGING DMX
CONSOLE CONNECTIONS.

DMX CONNECTIONS EXAMPLE

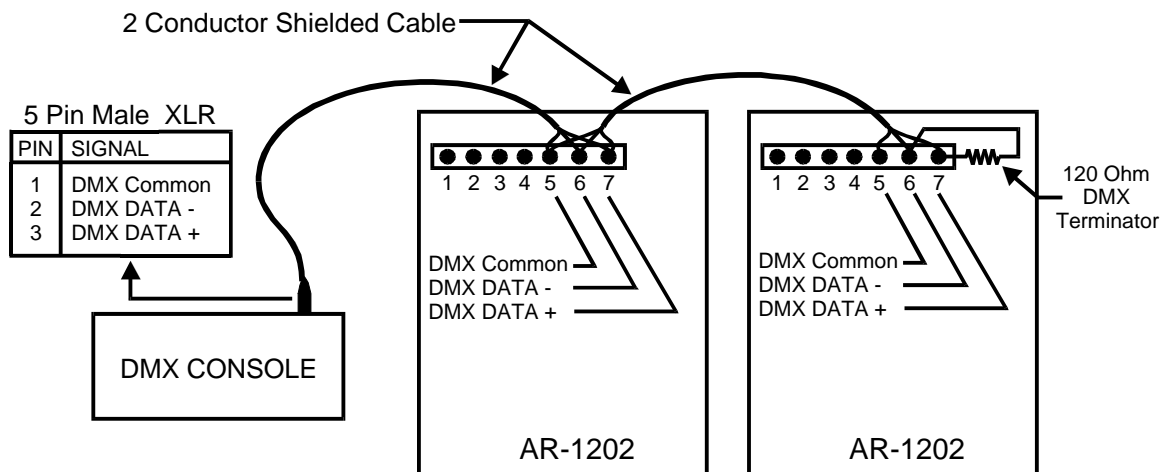

SMART REMOTE CONNECTIONS

There are two types of smart remotes (push button and fader) which can be used with the AR-1202. There are multiple models of each type. They all connect to a common RS-485 bus which is controlled by a AR-1202. Additional AR-1202 dimmers may also be connected on the same bus. One of them will be set as the master controller by making **UNIT ADDRESS ASSIGNMENTS**.

Smart remote signals to the AR-1202 are transmitted over a two twisted pair, shielded, low capacitance cable. One pair carries the RS-485 signal and the other provides a low voltage power and common to the remotes.

A smart remote bus should be daisy chained to all its receiving units. It should NOT be connected in a star arrangement with multiple "home runs".

Each smart remote has a 4 pin connector with screw down terminals to connect to the RS-485 bus. You must get the exact wiring pinout information for the remote unit from its owners manual.

CAUTION
 REMOVE ALL POWER FROM THE AR-1202 BEFORE MAKING OR CHANGING SMART REMOTE CONNECTIONS.

See the diagram "EXTERNAL CONNECTIONS" and the example below for specific connection information.

SMART REMOTES CABLE CONDUCTOR ARRANGEMENT FOR DUAL TWISTED PAIR, SHIELDED CABLE

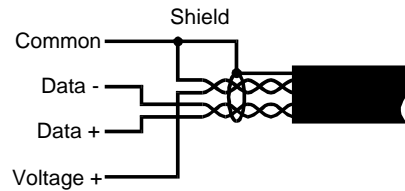

SMART REMOTE CONNECTIONS EXAMPLE

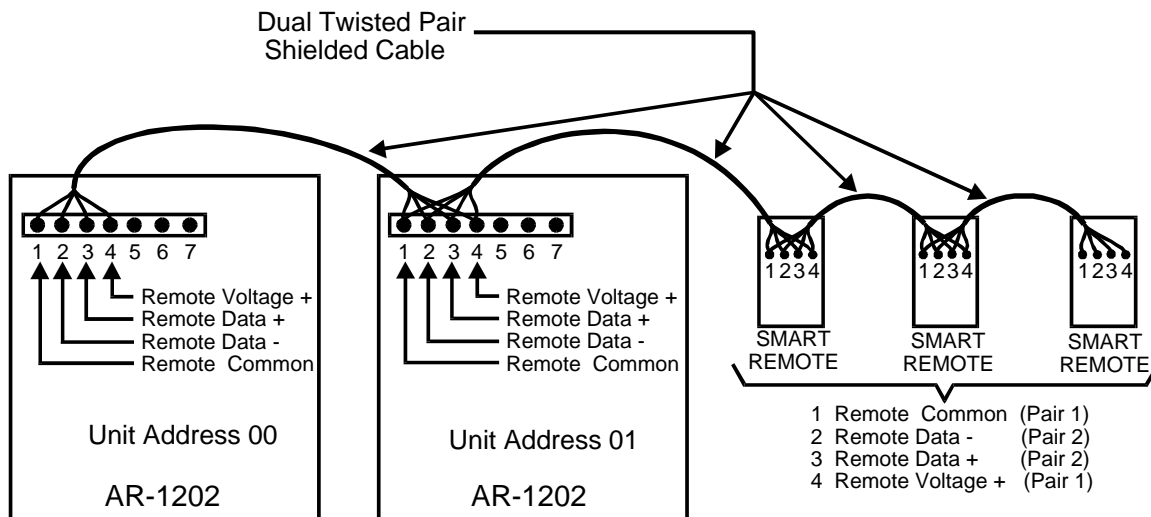

SIMPLE REMOTE CONNECTIONS

CAUTION
REMOVE ALL POWER FROM THE AR-1202 BEFORE MAKING OR CHANGING SIMPLE REMOTE CONNECTIONS.

When the switch is operated the closure brings the common back to the applicable simple remote scene number connection point at the AR-1202 terminal strip. Almost any available low voltage wire may be used since these connections are just contact closures.

Scenes 1 - 7 (stored in the AR-1202) may be used by simple remotes. A BLACKOUT function may also be accessed. A simple remote is any switch which can provide a momentary contact closure which can be applied to a specific pin on the AR-1202 SIMPLE REMOTE CONNECTIONS terminal strip.

Multiple simple remotes may be used. Additionally multiple AR-1202 units may be chained to one or more simple remotes

The SIMPLE REMOTE COMMON is routed to the remote switch.

See the diagram "EXTERNAL CONNECTIONS" and the example below for specific connection information.

SIMPLE REMOTE CONNECTIONS EXAMPLE USING A LIGHTRONICS APP01

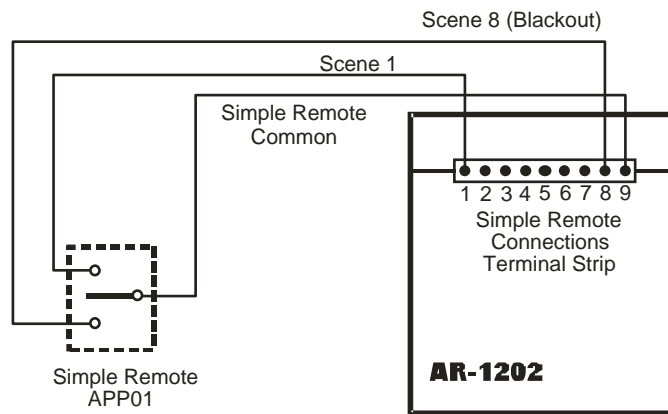

AR - 1202 UNIT SETUP

FRONT PANEL (PARTIAL VIEW)

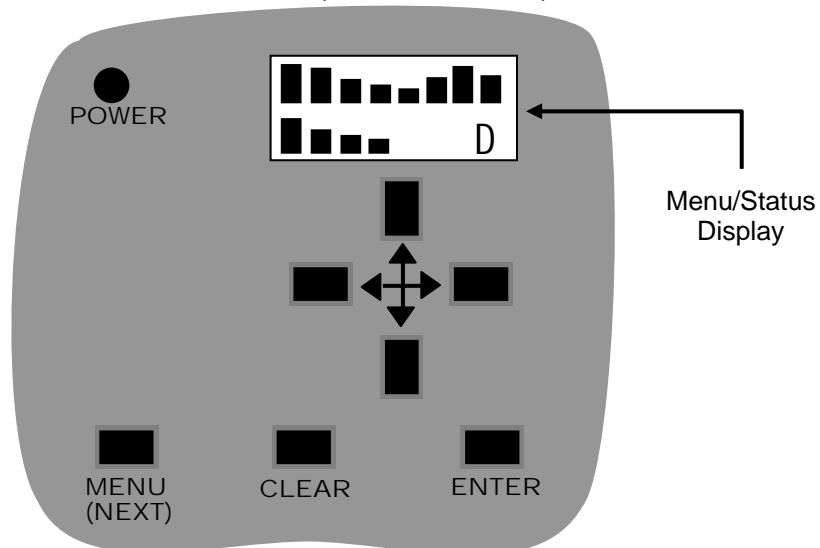

AR-1202 UNIT SETUP

The AR-1202 must be set up (configured) as part of the installation process. This process is done from the AR-1202 front panel using 5 menus described below.

SYSTEM SETUP should be done first. It includes: setting the System Mode, System ID, and System Power Setup.

DIMMER SETUP should be done next. It includes Channel Limiting and Dim/Non-Dim selections.

DMX I/O SETUP must be performed if the unit will be used with a DMX console. This setup assigns (patches) dimmer channels to DMX channels and can lockout the wall remote stations.

SCENE SETUP must be performed to create scene presets to be activated from the remote control stations or by the clock/timer subsystem.

EVENT SETUP must be done if the clock/timer subsystem will be used. It includes Setting the Clock and Programming Events.

TOP LEVEL MENUS LAYOUT

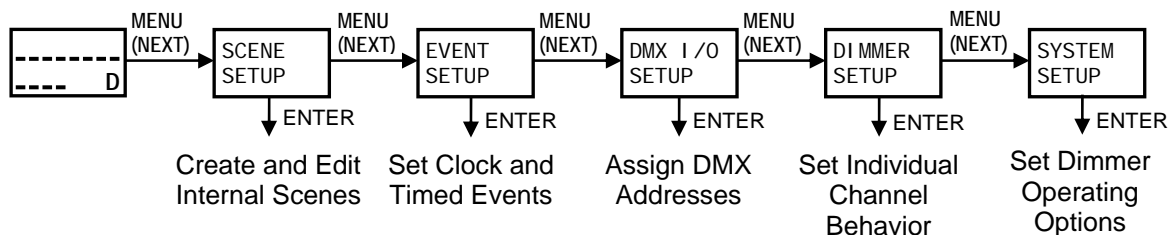

USING THE MENU SYSTEM

The MENU (NEXT) button steps through the five display menus. When one of these menus is displayed you can push the ENTER button to access that function. The CLEAR button will return the unit to its normal operating mode and cause the display to show the channel level bar graph. The CLEAR button DOES NOT clear entered values. The arrow buttons are used to set values for menu selections.

SYSTEM MODE

The AR-1202 currently uses only the NORMAL setting for system mode.

At the AR-1202 front panel - push MENU (NEXT) until the System Setup appears on the status display.

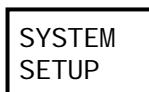

Push ENTER. The System Mode menu will be shown.

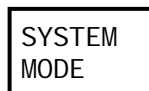

Push ENTER. The System Mode Selection menu will be shown.

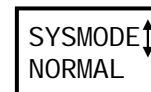

Use the ↑ and ↓ buttons to select the NORMAL mode. Push ENTER when finished.

SYSTEM POWER SETUP

CAUTION
TURN OFF ALL CHANNELS AND OPEN ALL CHANNEL CIRCUIT BREAKERS BEFORE CHANGING THE INPUT POWER SETUP.

In addition to making the correct power connections for the power source at your installation the AR-1202 must be set up to correctly respond to the power type.

At the AR-1202 front panel - push MENU (NEXT) until the System Setup menu appears on the Status display.



Push **ENTER**. Then push **MENU (NEXT)** until the System Power menu appears on the status display.

SYSTEM
POWER

Push **ENTER**. The display will show the current power configuration. For example:

SYSTEM
AR 3PhsN

Use the \uparrow and \downarrow buttons to select a configuration corresponding to the actual power being supplied to the AR-1202. Push **ENTER** when correct power is shown. The available choices are shown below.

AR 1PhsN Single Phase 120/240V Power Source
 AR 3PhsN 3 Phase 120/208V Power Source
 Normal Phase Rotation
 AR 3PhsR 3 Phase 120/208V Power Source
 Reverse Phase Rotation

There are two additional settings which are used only when it is not possible to provide actual 120/240V Single Phase power and the unit is being powered by 2 phases of a 120/208V 3 Phase source.

AR 2PhsN 2 Phase 120/208V Power Source
 Normal Phase Rotation
 AR 2PhsR 2 Phase 120/208V Power Source
 Reverse Phase Rotation

NOTE: There are 2 other settings available in this menu. These do not apply to the AR-1202 dimmer.

You may not know in advance if you should use the Normal or Reverse rotation choice for 3 phase or 2 Phase power. If this is the case then use NORMAL phase rotation.

NO damage will occur if the rotation is actually reversed but dimming will not occur correctly and some channels will appear to be in a on/off mode. This will be readily apparent when operating the unit. You can then change the setting.

UNIT ADDRESS ASSIGNMENT

When using a single AR-1202 unit system, the unit address **MUST BE SET TO 00**. One (and only one) of the units in a multiple unit system must be set to address 00. Other units should be assigned in a consecutive order.

At the AR-1202 front panel - push **MENU (NEXT)** until the System Setup appears on the status display.

SYSTEM
SETUP

Push **ENTER**. Then push **MENU (NEXT)**. The System ID Set menu will be shown.

SYSTEM
ID SET

Push **ENTER**. The display shows the unit address.

SET UNIT
ID \updownarrow 00

Set the desired address by pushing the \uparrow and \downarrow buttons.

Push **ENTER**. Then push **CLEAR** to return to the normal operating mode.

DIMMER CHANNEL SETUP

Individual channels within the AR-1202 dimmer can be set for different behaviors. Any channel may be limited to a user selected maximum intensity level. Limiting applies to manual, scene, and DMX operation. Any channel may also be set to run as NON-DIM (or RELAY).

CHANNEL LIMITING

At the AR-1202 front panel - push **MENU (NEXT)** until the Dimmer Setup menu appears on the display.

DIMMER
SETUP

Push **ENTER**. The Channel Limit menu will be shown.

\leftarrow 01 \rightarrow LMT
255 \updownarrow

Use the \rightarrow and \leftarrow buttons to select a channel. Then use the \downarrow and \uparrow buttons to set its limiting value. Push **ENTER** when finished. The limit range on the menu is between 10 and 255 which corresponds to lighting intensity of between 4 and 100 percent.

CHANNEL NON-DIM (RELAY) MODE

To set a channel to Non-Dim: Push **MENU (NEXT)** until the Dimmer Setup menu appears on the display.



DI M M E R
S E T U P

Push **ENTER**. Then push **MENU (NEXT)**. The display will show the menu:

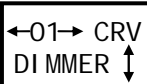

←01→ CRV
DI M M E R ↑

Use the → and ← buttons to select a channel. Then use the ↓ and ↑ buttons to switch between DIMMER and NON-DIM. Push **ENTER** when finished.

DMX I/O SETUP

DMX I/O Setup consists of two functions. Dimmer channel assignment and Remote lockout

DIMMER CHANNEL ASSIGNMENT

Dimmer channel assignment is used to assign individual AR-1202 channels (circuits) to a DMX control channel. Each dimmer channel (1 - 12) is fully patchable to any of 512 DMX control channels.

At the AR-1202 front panel - push **MENU (NEXT)** until the DMX I/O Setup menu appears on the display.



DMX I / O
S E T U P

Push **ENTER**. The display shows AR-1202 dimmer channels on the top line. The currently assigned DMX channel is shown on the lower line prefixed by "DMX".

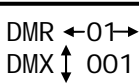

DMR ←01→
DMX ↑ 001

Use the → and ← buttons to select a dimmer channel.

Then use the ↓ and ↑ buttons to assign it to a DMX channel. Push **ENTER** after each channel assignment. Push **CLEAR** to exit from the menu. It will not clear your settings.

CONSOLE LOCKOUT: You can set any dimmer channel output to ignore DMX signal inputs from a DMX console by assigning it to DMX channel 0. This feature can be used with house lights or other special lighting. The channel will still respond to wall remotes but the DMX console will be ignored.

REMOTE LOCKOUT

The Remote Lockout function prevents the AR-1202 from responding to the smart remote wall stations when a DMX signal from a console is present. Simple remote stations will still function.

At the AR-1202 front panel - push **MENU (NEXT)** until the DMX I/O Setup menu appears on the display.



DMX I / O
S E T U P

Push **ENTER**. Then push **MENU (NEXT)**. The display will show the lockout menu.

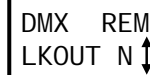

DMX REM
LKOUT N ↓

Use the ↓ and ↑ buttons to select ON or OFF. Push **ENTER** when the desired state is shown.

CREATING AND EDITING SCENES

At the AR-1202 front panel - push **MENU (NEXT)** until the Scene Setup menu appears on the display.

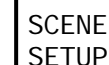

SCENE
S E T U P

Push **ENTER**. The display shows the current scene number.

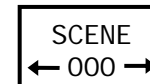

SCENE
← 000 →

Use the ← and → buttons to select the scene you want to set up and push **ENTER**. Scene 00 controls blackout fade time. Scene 01 is the first actual scene.

There are three ways to create or set up a scene:

1. Set each channel intensity manually (**EDIT SCENE**)
2. Copy another existing scene (**COPY SCENE**). You can then edit the results.
3. Record a snapshot of the current channel intensities (**RECORD LIVE NOW**)

Push **MENU (NEXT)** to select one of the 3 methods described above. The display will show the corresponding menu.

TO CREATE A SCENE MANUALLY

Push **ENTER** when **EDIT SCENE** is shown.

The current channel number is shown on the display upper left. The current scene number (which was selected in the previous step) is shown on the display upper right. The settings for three channels are shown on the lower display row.

The **LEFT** channel on the display is the Current Channel (the channel which you will set the intensity level for).

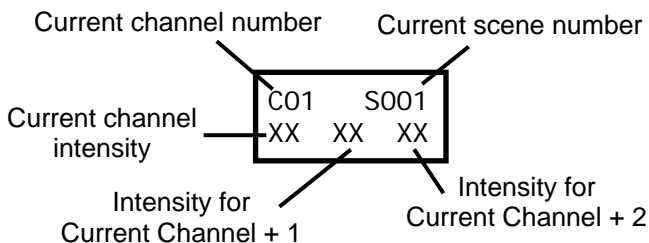

Use the **↓** and **↑** buttons to set the channel output intensity. The display shows the intensity setting as a number between 0% and 100%. A 100% setting is indicated by "FL". A "XX" setting means that the channel will be ignored for the current scene.

Push **ENTER** after the channel level is set.

Use the **←** and **→** buttons to proceed to the next channel to be set up. The lower row of the display will shift to the left. Repeat the channel intensity selection for that channel.

Push **CLEAR** when all the channels for the selected scene are set. This will not clear your scene settings.

To setup another scene - repeat the process above using a different scene selection.

TO COPY A SCENE

Push **ENTER** when **COPY SCENE** is shown. The display will show a menu so you can select an existing scene to copy from.

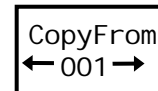

Use the **→** and **←** buttons to select a scene. Then push **ENTER**. The scene will be copied and you will be transferred to the **EDIT SCENE** menu where you can further adjust the scene if desired.

TO RECORD A LIVE SCENE

A scene may be created by recording the current channel intensity levels.

Push **ENTER** when **RECORD LIVE NOW** is shown.

The existing channel intensities will be recorded to the scene and you will be transferred to the **Edit Scene** menu where you can adjust the scene if desired.

SCENE FADE TIME

A fade time may be set individually for each scene. This is the time elapsed between a scene fully active and the next scene fully active. The factory default fade time is 3 seconds.

Fade time may be set between .5 and 99.5 seconds and is set from the **SCENE SETUP** menu (usually as you set channel intensities for the scene).

1. To set a scene fade time - Access the **EDIT SCENE** menu for the desired scene.
2. Use the **→** and **←** buttons to move **BEYOND** the last channel (**CHANNEL 16**) for the scene. The display will indicate the current fade time for the scene.
3. Use the **↓** and **↑** buttons to set the desired fade time. Then push **ENTER**.
4. Push **CLEAR** to select another scene for fade time set up.

SCENE BLACKOUT FADE TIME

Fade time for the remote stations blackout function is set as an independent function.

The procedure is similar to that for other scenes except the blackout fade time is accessed by selecting SCENE 00 from the SCENE SETUP menu. Factory default fade time is 3 seconds. Blackout fade time may be set between 0.5 and 99.5 seconds. To select a fade time - use the ↓ and ↑ buttons. Push **ENTER** when the desired time is shown.

OPERATION

MANUAL OPERATION

Individual dimmer channels may be operated from the AR-1202 front panel. This is useful during testing and setup operations. Use the → and ← buttons to select a channel. The associated channel on the bar graph display will flash. Use the ↓ and ↑ buttons to set the lighting intensity for the selected channel.

Manual operation combines with DMX and remote stations settings but does not lock them out.

The **CLEAR** button will turn off all channels when operating manually.

DMX CONSOLE OPERATION

If a DMX signal is present when the AR-1202 is turned on it will automatically respond to it.

A "D" will be shown in the lower right corner of the LCD display if a valid DMX signal is present. Channel intensity levels will be shown on the bar graph display.

CHANNEL INTENSITY BAR GRAPH

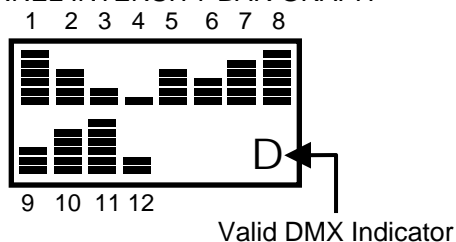

SMART REMOTES OPERATION

The AR-1202 can store 100 preset scenes. Most of these can be activated by smart remotes. See the section "Creating and Editing Scenes" for info about programming the scenes. These scenes are grouped according to which type of smart remote can access them. Scenes 1 - 48 are reserved for push button and IR remotes. Scenes 51 - 99 are used with fader remotes. If multiple AR-1202 units are connected to a smart remote then each AR-1202 will activate its own corresponding scene.

Both push button and fader remotes may be connected to the same smart remote bus.

BUTTON AND IR SMART REMOTES OPERATION

These remotes activate individual scenes within a block of scenes which have been stored in the AR-1202. Scenes will activate on an "exclusive" basis. In other words only one scene may be on at a time. Currently available remotes are the AC-1009, AC-2016 and AI-1001.

You can select which block of scenes will be activated by the remote. This is done by DIP switches on the back of the remote. For instance, an AC-1009 can be set to control scenes 1 - 8, scenes 9-16, or other blocks of 8 consecutive scenes. There are a total of 6 scene blocks available covering scenes 1 thru 48.

The scene activation buttons will toggle. In other words a scene will go OFF if you push its button while the scene is active.

The OFF button invokes a system wide BLACKOUT. (all scenes will be turned off regardless of their source).

Refer to the smart remote owner manual for specific info on setting scene addressing. Multiple remotes of this type may be but are not required to be set to the same block of scenes.

FADER SMART REMOTES OPERATION

These units use specific individual scenes which have been stored in the AR-1202 on a "pile on" basis. In other words multiple scenes will merge together in a "greatest of" fashion. This means that the intensity of any given channel will go to the highest level of all the scenes which use it.

Currently available fader remotes are the AF-2004, AF-3007 and the AF-5013.

Fader remotes are scene block addressable so you can select which scenes will be activated it. There are 3 scene blocks available. Each block includes 16 scenes. The first block starts at scene 51. This refers to the lowest numbered fader on the remote. The other faders on that remote will use the next consecutively numbered scenes (52, 53, 54, etc.). The 2nd and 3rd scene blocks begin at scene 67 and 83 respectively.

Multiple remotes of this type may be but are not required to be set to the same block of scenes. Refer to the fader smart remote owner manual for specific info on setting scene blocks.

SIMPLE REMOTES OPERATION

Scenes 1 - 7 (stored in the AR-1202) may be accessed by simple remotes. A BLACKOUT FUNCTION may also be accessed. A simple remote is any switch which can provide a momentary contact closure that can be applied to a specific pin on the AR-1202 SIMPLE REMOTE UNIT INPUTS terminal strip. Lightronics currently offers a APP01 simple remote.

This is a "center off , single pole, double throw, momentary toggle switch". It can be used as a simple entrance switch to activate a scene when someone enters an area. Alternative devices such as relays, timers, and motion sensors can be connected to AR-1202 dimmers as simple remotes. These are available from a variety of manufacturers.

Operation of a simple remote is dependent upon the device used. In the case of the Lightronics APP01 it is a simple matter of pushing the switch.

EVENT SYSTEM OPERATION

The AR-1202 includes an internal clock and timer sub system. This subsystem may be used to create events which activate and switch between preset lighting scenes based upon times, days, and dates. A total of 128 events may be programmed.

The clock operates without AC power for aprox. 2 weeks and does not require a battery. Event settings are retained in non volatile memory therefore they will not be lost if the AR-1202 powered off.

An event is used to trigger any one of 100 scenes

which have been previously created and stored in the AR-1202. Any scene may be used by multiple events. A scene may be set to turn ON, or OFF, or be ignored by an event.

An event may be set to trigger based on a date of the year and a time. This enables scene activation for one time or infrequent occurrences such as holidays.

An event may also be set to trigger on a daily or multiple times per day basis. Additionally specific days of a week can be designated to be used or skipped. This is a more common type of operation where events are triggered on a regular schedule.

SETTING THE INTERNAL CLOCK

The clock must be set to the correct date, time and day of the week in order to operate correctly. This is performed from the AR-1202 Event Set Clock menu

At the AR-1202 front panel - push **MENU (NEXT)** until the Event Setup menu appears on the display.

EVENT
SETUP

Push **ENTER**. Then push **MENU (NEXT)**. The Event Set Clock menu will be shown.

EVENT
SETCLOCK

Push **ENTER**. The Set Date menu will be shown.

SET DATE
00/00/00

SETTING THE DATE

Use the **←** and **→** buttons to select either the month, day, or year and then use the **↑** and **↓** buttons to set the value. Push **ENTER** after setting each value. Push **MENU (NEXT)** to proceed to the Set Time menu.

SETTING THE TIME OF DAY

SET TIME
00:00

Use the **←** and **→** buttons to select either hours or minutes and then use the **↑** and **↓** buttons to set the value. Push **ENTER** after setting each value.

Push **MENU (NEXT)** to proceed to the Set Day menu.



SETTING THE DAY OF THE WEEK

The day of the week **MUST BE SET** when setting or changing the date. It does not automatically synchronize to the date setting. Once the day is correctly set it will continue to track the date.

Use the **↑** and **↓** buttons to select the day so that it corresponds correctly to the previously set date. Push **ENTER** when the correct day is shown.

A complete layout diagram of the menus for setting the clock is shown below.

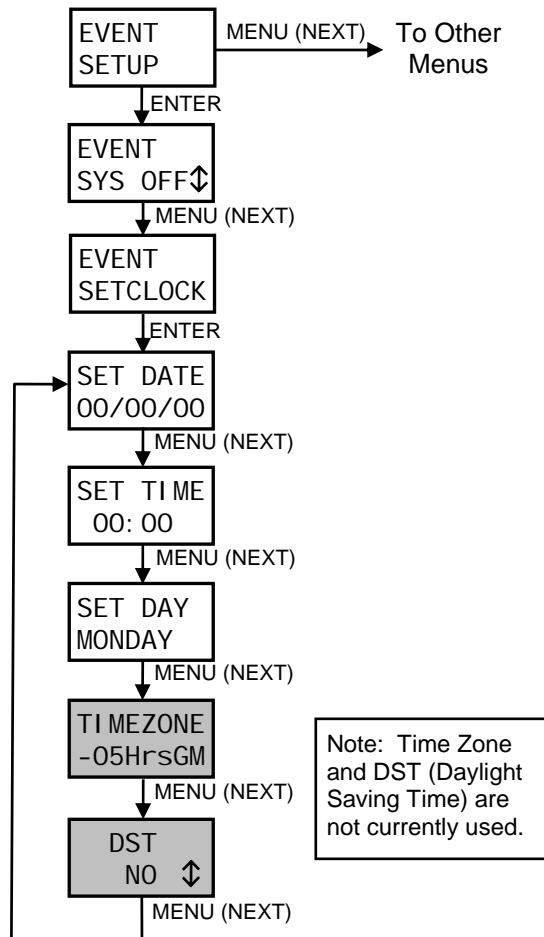

EVENT SYSTEM ENABLE

Events programmed in the AR-1202 will not trigger unless the event system is set to ON. If the event system is OFF you can still set the clock and program

event times and dates but they will never be triggered.

Turning events OFF is used to prevent triggers which may have been forgotten about, incorrectly set, or otherwise unaccounted for.

TO CONTROL EVENT TRIGGERING

Push **ENTER** from the Event Setup menu. The display will show the event system ON/OFF menu.

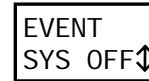

Use the **↑** and **↓** button to select ON or OFF. Push **ENTER** when the desired ON/OFF state is shown.

PROGRAMMING EVENTS

Events are programmed using the AR-1202 Event Editor menus. The menu layout is shown below.

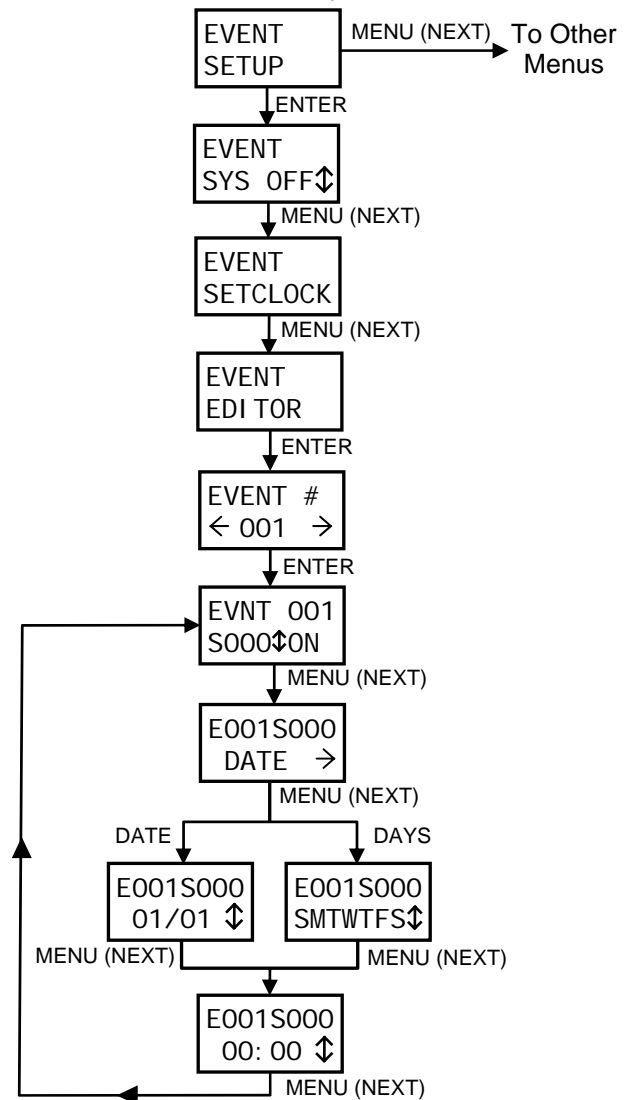

Programming an event consists of four steps:

1. Select the event you want to set up (1 - 128).
2. Assign a scene (1 - 100) to the event.
3. Select what action is to be performed for that scene (Turn it ON, Turn it OFF, or IGNORE IT).
4. Assign the DATE/ TIME or DAY(S) / TIME for the event to be triggered.

SELECTING AN EVENT

From the EVENT EDITOR menu - Push **ENTER**. The display will show the event selection menu as follows.

```
EVENT #
< 001 >
```

If an event already has a scene assigned to it then the event number will be followed by an asterisk (*).

Use the **←** and **→** buttons to select the event number. Then push **ENTER** to proceed to the scene number and scene action menu. If you push and hold down the **←** or **→** button - the event number will skip to the next programmed event and stop.

ASSIGNING A SCENE AND SCENE ACTION

The top row of this menu shows the number of the event you are working on. The bottom row shows the assigned scene and the action to perform.

```
EVNT 001
S000↓ON
```

Use the **←** and **→** buttons to select either the scene number or action. Your selection is indicated by flashing that part of the menu. Use the **↑** and **↓** buttons to change the value. Scenes 0 - 100 may be assigned. Available actions are ON, OFF, and XXX (IGNORE). Push **ENTER** once a value has been selected. A setting of XXX disables of the event even if a scene for it has been set.

Push **MENU (NEXT)** to proceed to the next menu or push **CLEAR** to revert to the event number selection menu.

CHOOSING DATE OR DAY BASED EVENTS

This menu enables selection of either DATE based or DAY based operation. The menu will show either

```
E001S000    OR    E001S000
DATE →      DAYS →
```

The top row shows the event number and scene number you are working on.

Use the **←** and **→** buttons to switch between DATE and DAYS. Push **MENU (NEXT)** to proceed to the next menu for setting the date or day and the time of day. Push **CLEAR** to revert to the event number selection menu.

SETTING DATE BASED TRIGGERS

The top row of these menus show the event and scene number you are working on.

The bottom row is used to set the trigger date and the time of day.

```
E001S000
01/01 ↓
```

To set the date:

Use the **←** and **→** buttons to select either the month or day of the month. Your selection is indicated by flashing that part of the menu. The date format is MM/DD (month on the left). Use the **↑** and **↓** buttons to change the value. Push **ENTER** once a value has been selected.

CAUTION: If you set an invalid date (such as February 30th) there will be no warning and the event will NEVER trigger.

Push **MENU (NEXT)** to proceed with setting the trigger time or push **CLEAR** to revert to the event number selection menu.

```
E001S000
00:00 ↓
```

To set the trigger time:

Use the **←** and **→** buttons to select hours or minutes. Your selection is indicated by flashing that part of the menu. The format for hours is 0 - 24 (not AM/PM). Use the **↑** and **↓** buttons to change the value. Push **ENTER** once a value has been selected.

Push **MENU (NEXT)** to revert to the SCENE NUMBER and SCENE ACTION menu or push **CLEAR** to revert to the event number selection menu.

SETTING DAY BASED TRIGGERS

The top row of these menus show the event number and scene number you are working on. The bottom row is used to set the trigger days and the time of day.

AR – 1202RTC ARCHITECTURAL DIMMER OWNERS MANUAL

Revision 1.93

06/03/2008

To set days of the week:

E001S000
 SMTWTFSD

The bottom menu row shows the days. If a day shows as a solid block (■) instead of a character then the event will be skipped (will not trigger on that day).

Use the ← and → buttons to select a week day. Then use the ↑ and ↓ buttons to change between trigger and skip. Push **ENTER** once a value has been selected.

Push **MENU (NEXT)** to proceed with setting the trigger time or push **CLEAR** to revert to the event number selection menu.

To set the trigger time:

E001S000
 00: 00 ↓

Use the ← and → buttons to select hours or minutes. Your selection is indicated by flashing that part of the menu. The format for hours is 0 - 23 (not AM/PM).

Use the ↓ and ↑ buttons to change the value. Push **ENTER** once a value has been selected.

Push **MENU (NEXT)** to revert to the SCENE NUMBER and SCENE ACTION menu or push **CLEAR** to revert to the event number selection menu.

MAINTENANCE AND REPAIR

OWNER MAINTENANCE

There are no user serviceable parts inside the unit.

INTERNAL FUSE

WARNING



MAKE CERTAIN POWER IS REMOVED
FROM THE FEED CIRCUITS
BEFORE HANDLING THE UNIT.



The AR-1202 has a 1/2 amp, 250V, Type ABC, fast acting fuses on the inside the cabinet. It provides protection only for the internal electronic control circuitry. It may be replaced **ONLY** by a fuse of identical type and size.

Contact a qualified electrical maintenance person if you suspect this fuse has blown.

HIGH VOLTAGE CIRCUITRY IS EXPOSED WHEN THE CABINET DOOR IS OPEN. DO NOT ALLOW THE UNIT TO OPERATE OR HAVE POWER APPLIED TO IT WHILE THE DOOR IS OPEN.

The best way to prolong the life of your unit is to keep is cool, clean, and dry. It is important that the cooling intake and exit vent holes are clean and unobstructed.

Service by other than Lightronics authorized agents may void your warranty.

OPERATING AND MAINTENANCE ASSISTANCE

If service is required, contact the dealer from whom you purchased the equipment or contact:

Lightronics, Service Department
509 Central Drive
Virginia Beach, VA 23454
TEL 757 486 3588.

Lightronics recommends that you record the serial number of your unit for future reference.

SERIAL NUMBER _____

CONTROL CIRCUIT BOARD CONNECTIONS

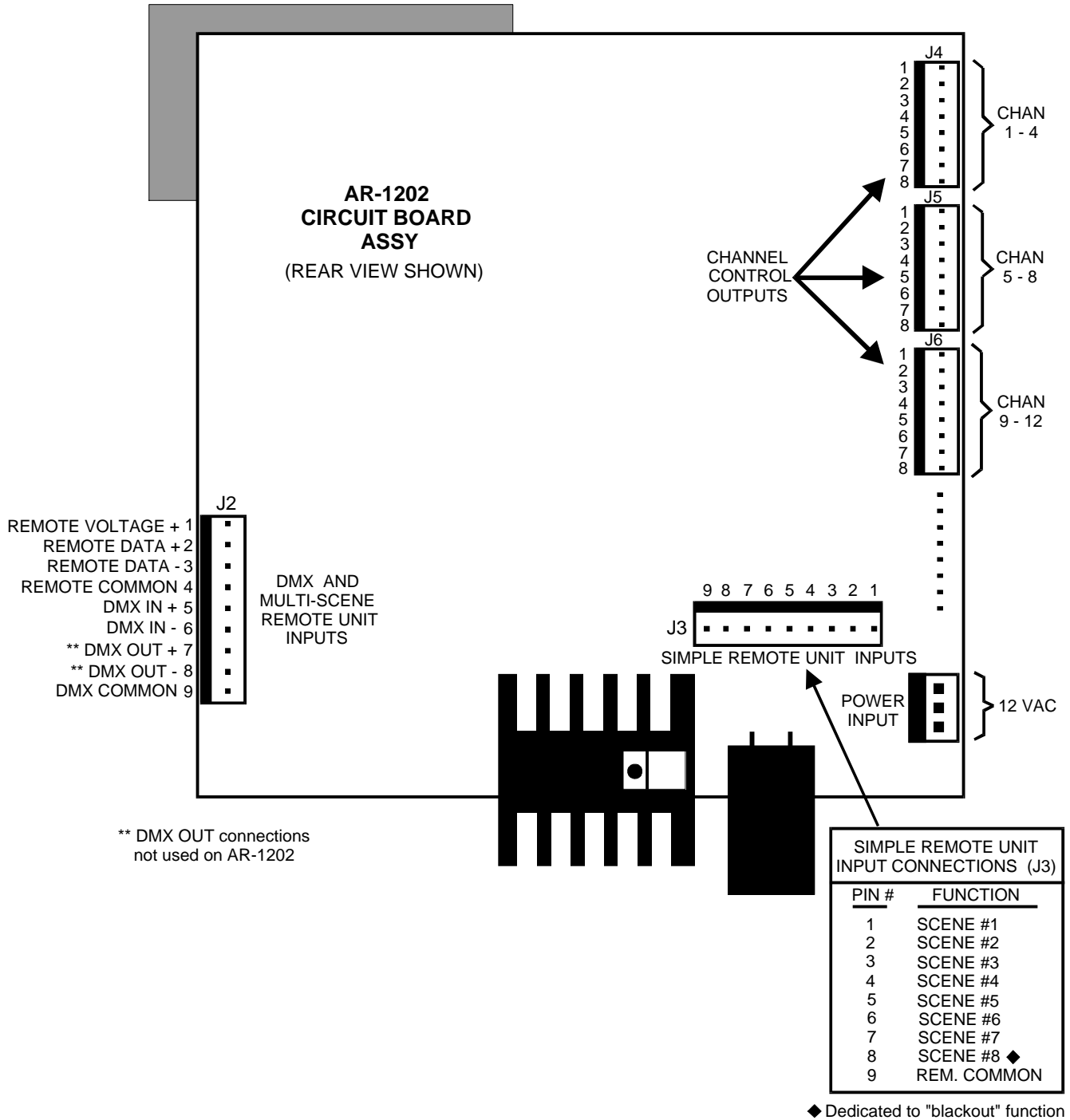

AR – 1202RTC ARCHITECTURAL DIMMER
OWNERS MANUAL

Revision 1.93

06/03/2008

DIMENSIONS AND MOUNTING

Cabinet Front View With Door Removed

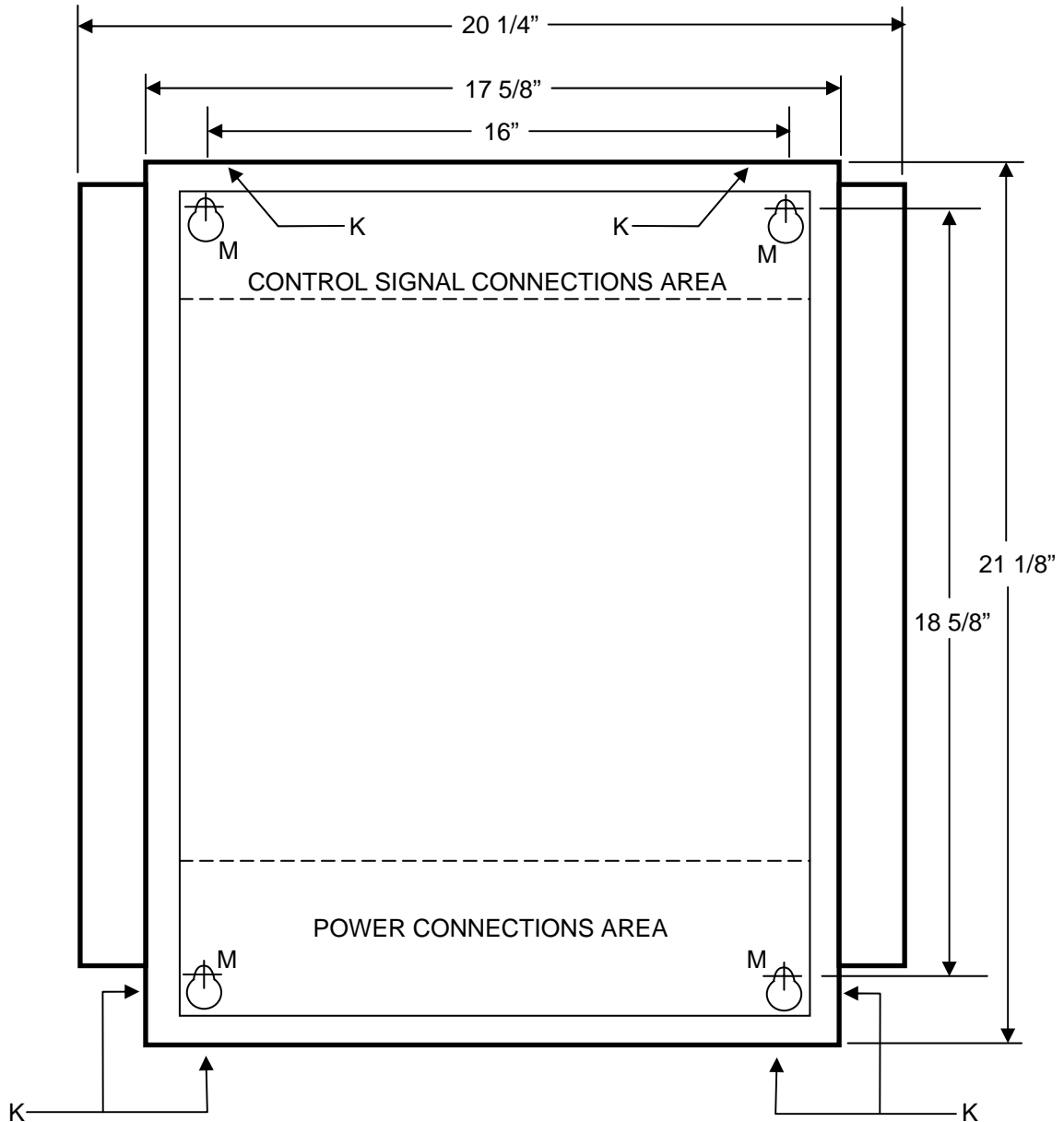

NOTES:

Dimensions are +/- 1/16". This drawing is not to scale.

Cabinet Clearance Depth is 6 1/4"

Mounting holes indicated by "M" will accommodate 1/4" bolt.

Double 1/2, 3/4 inch knockout holes provided at locations indicated by "K".

Suggested Mounting Procedure:

Drill top holes level, 16" apart at desired height.

Partially install bolts (enough to hold cabinet weight).

Hang cabinet from top bolts.

Drill lower holes and install lower bolts – tighten all bolts.

AR-1202 UNIT SPECIFICATIONS

CHANNELS/CAPACITY:	12 Channels @ 2400 Watts each channel
POWER REQUIREMENTS:	120/208VAC three phase,80 Amps each line OR 120/240VAC single phase, 120 Amps each line
POWER DEVICES:	Dual 65 Amp SCRs
POWER CONNECTOR:	Terminal strip
CHANNEL OUTPUT:	Terminal Strip
CIRCUIT BREAKERS:	20 Amp fast acting
MINIMUM LOAD:	15 Watts
CURVE:	Modified square law
FILTER RISE TIME:	600 usec. minimum
OUTPUT FUNCTION:	DIMMER or RELAY selectable
CONTROL INPUT:	DMX-512 U.S.I.T.T. standard
FRONT PANEL:	8 char. x 2 line LCD display
REMOTE NETWORK:	RS-485, 62.5 Kbaud, bidirectional 9 bit network
LOCAL PRESETS:	100 scenes standard. Expandable to 255 scenes
CLOSURE INPUT:	8 inputs for single, dual button, or combine stations
REMOTE STATIONS:	Total of 32 remote stations with unique system addresses
SLAVE UNITS:	Up to 31 additional units may be added
SIZE :	21 1/8"H x 20 1/4"W x 6 1/4"D
WEIGHT:	61 lbs (70 lbs shipping weight)



WARRANTY

All Lightronics products are warranted for a period of TWO/FIVE YEARS from the date of purchase against defects in materials and workmanship.

This warranty is subject to the following restrictions and conditions:

- A) If service is required, you may be asked to provide proof of purchase from an authorized Lightronics dealer.
- B) The FIVE YEAR WARRANTY is only valid if the warranty card is returned to Lightronics accompanied with a copy of the original receipt of purchase within 30 DAYS of the purchase date, if not then the TWO YEAR WARRANTY applies. Warranty is valid only for the original purchaser of the unit.
- C) This warranty does not apply to damage resulting from abuse, misuse, accidents, shipping, and repairs or modifications by anyone other than an authorized Lightronics service representative.
- D) This warranty is void if the serial number is removed, altered or defaced.
- E) This warranty does not cover loss or damage, direct or indirect arising from the use or inability to use this product.
- F) Lightronics reserves the right to make any changes, modifications, or updates as deemed appropriate by Lightronics to products returned for service. Such changes may be made without prior notification to the user and without incurring any responsibility or liability for modifications or changes to equipment previously supplied. Lightronics is not responsible for supplying new equipment in accordance with any earlier specifications.
- G) This warranty is the only warranty either expressed, implied, or statutory, upon which the equipment is purchased. No representatives, dealers or any of their agents are authorized to make any warranties, guarantees, or representations other than expressly stated herein.
- H) This warranty does not cover the cost of shipping products to or from Lightronics for service.
- I) Lightronics Inc. reserves the right to make changes as deemed necessary to this warranty without prior notification.